

Approved by:

Checked by:

Issued by:

SPECIFICATION

PRODUCT: SAW FILTER

MODEL: HDBF31A2M SIP5K



SHOULDER ELECTRONICS LIMITED

1.SCOPE

SHOULDER's SAW filter series have broad line up products meeting all broadcast standard including NTSC,PAL and SECAM systems. These filters are composed of two interdigital transducers on a single-crystal, piezoelectrical chip. they are used in electronic equipments such as TV and so on.

2.Construction

2.1 Dimension and materials

Manufacturer's name : SHOULDER ELECTRONICS Co. LTD(CHINA)

Type: BF31A2M

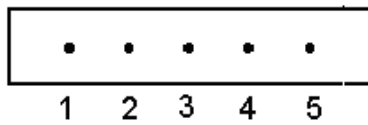

Unit:mm

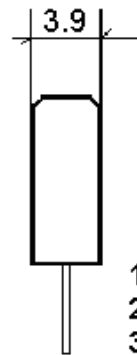
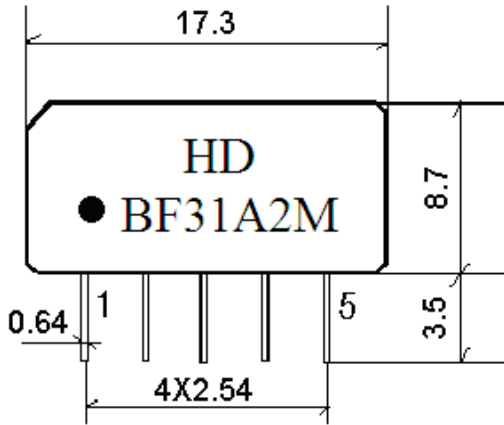

- 1 Input
- 2 Input-ground
- 3 ground
- 4 Output
- 5 Output

2.2. Circuit construction, measurement circuit

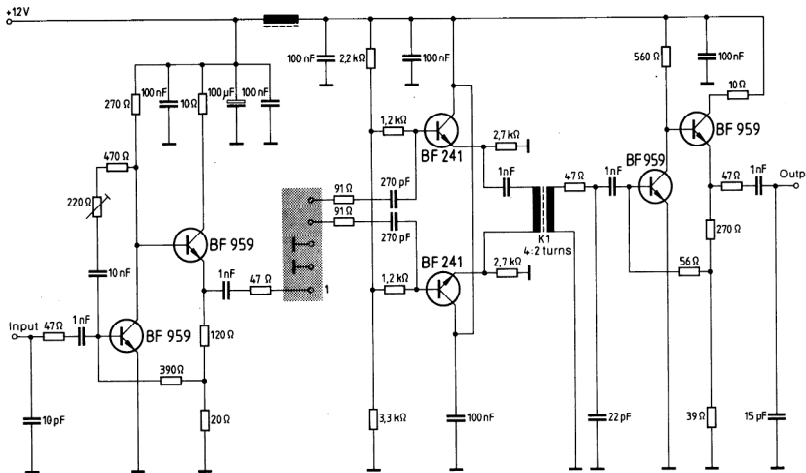

Test circuit for SIP-5 filter
Input impedance of the symmetrical post-amplifier: 2 kΩ in parallel with 3 pF

3.Characteristics

Items	Conditions	Specifications
Standard atmospheric conditions	Unless otherwise specified , the standard rang of atmospheric conditions for making measurements and tests is as follows; Ambient temperature : 15°C to 35°C Relative humidity : 25% to 85% Air pressure : 86kPa to 106kPa	There shall be no damage.
Operating temperature rang	Operating temperature rang is the rang of ambient temperatures in which the filter can be operated continuously. -10°C ~ +60°C	
Storage temperature rang	Storage temperature rang is the rang of ambient temperatures at which the filter can be stored without damage. Conditions are as specified elsewhere in these specifications. -40°C ~ +70°C	
Reference temperature	+25°C	

3.1 Maximum Rating

DC voltage	VDC	12	V	Between any terminals
AC voltage	Vpp	10	V	Between any terminals

3.2 Electrical Characteristics

Source impedance

$$Z_s=50 \Omega$$

Load impedance

$$Z_L=2k \Omega //3pF$$

$$T_A=25^\circ C$$

Item	Freq	min	typ	max	
Center frequency (center between 10dB point)	F ₀	-	31.00	-	MHz
Insertion attenuation Reference level	31.00MHz	-	16.5	18.5	dB
Pass bandwidth	B3dB	-	0.5	-	MHz
	B30dB	-	1.7	2.0	MHz
Sidelobe	22.60~28.60MHz	35.0	62.0		dB
	28.60~29.80MHz	32.0	50.0		dB
	32.20~33.40MHz	32.0	50.0		dB
	33.40~42.60MHz	35.0	52.0		dB
Temperature coefficient		-18			ppm/k

3.3 Environmental Performance Characteristics

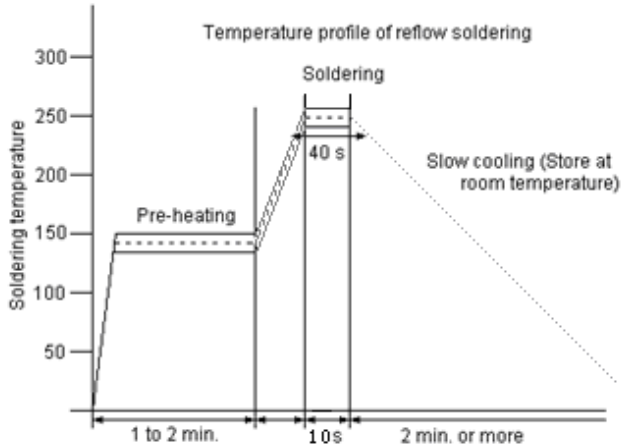
Item	Condition	Specifications																					
High temperature	The specimen shall be store at a temperature of $80\pm 2^{\circ}\text{C}$ for $96\pm 4\text{h}$. Then it shall be subjected to standard atmospheric conditions for 1h, after which measurement shall be made within 1h.	Mechanical characteristics and specifications in electrical characteristics shall be satisfied. There shall be no excessive change in appearance.																					
Low temperature	The specimen shall be store at a temperature of $-20\pm 3^{\circ}\text{C}$ for $96\pm 4\text{h}$. Then it shall be subjected to standard atmospheric conditions for 1h, after which measurement shall be made within 1h.																						
Humidity	The specimen shall be store at a temperature of $40\pm 2^{\circ}\text{C}$ with relative humidity of 90% to 96% for $96\pm 4\text{h}$. Then it shall be subjected to standard atmospheric conditions for 1h, after which measurement shall be made within 1h.																						
Thermal shock	<p>The specimen shall be subjected to 8 continuous cycles each as shown below. Then it shall be subjected to standard atmospheric conditions for 1h, after which measurement shall be made within 1h.</p> <table border="1" data-bbox="448 954 1018 1249"> <thead> <tr> <th></th> <th>Temperature</th> <th>Duration</th> </tr> </thead> <tbody> <tr> <td>1</td> <td>$+25^{\circ}\text{C} \Rightarrow -40^{\circ}\text{C}$</td> <td>0.5h</td> </tr> <tr> <td>2</td> <td>-40°C</td> <td>4h</td> </tr> <tr> <td>3</td> <td>$-40^{\circ}\text{C} \Rightarrow +85^{\circ}\text{C}$</td> <td>2h</td> </tr> <tr> <td>4</td> <td>$+85^{\circ}\text{C}$</td> <td>4h</td> </tr> <tr> <td>5</td> <td>$+85^{\circ}\text{C} \Rightarrow +25^{\circ}\text{C}$</td> <td>0.5h</td> </tr> <tr> <td>6</td> <td>$+25^{\circ}\text{C}$</td> <td>1h</td> </tr> </tbody> </table>			Temperature	Duration	1	$+25^{\circ}\text{C} \Rightarrow -40^{\circ}\text{C}$	0.5h	2	-40°C	4h	3	$-40^{\circ}\text{C} \Rightarrow +85^{\circ}\text{C}$	2h	4	$+85^{\circ}\text{C}$	4h	5	$+85^{\circ}\text{C} \Rightarrow +25^{\circ}\text{C}$	0.5h	6	$+25^{\circ}\text{C}$	1h
	Temperature		Duration																				
1	$+25^{\circ}\text{C} \Rightarrow -40^{\circ}\text{C}$		0.5h																				
2	-40°C	4h																					
3	$-40^{\circ}\text{C} \Rightarrow +85^{\circ}\text{C}$	2h																					
4	$+85^{\circ}\text{C}$	4h																					
5	$+85^{\circ}\text{C} \Rightarrow +25^{\circ}\text{C}$	0.5h																					
6	$+25^{\circ}\text{C}$	1h																					
Resistance to Soldering heat	<p>Reflow soldering method Peak: $255 \pm 5^{\circ}\text{C}$, $220 \pm 5^{\circ}\text{C}$, 40s At electrode temperature of the specimen.</p>  <p>The specimen shall be passed through the reflow furnace with the condition shown in the above profile for 1 time. The specimen shall be stored at standard atmospheric conditions for 1h, after which the</p>																						

	measurement shall be made. Test board shall be 1.6 mm thick. Base material shall be glass fabric base epoxy resin.	
Solder ability	Immerse the pins melt solder at 260°C+5/-0°C for 5 sec.	More then 95% of total area of the pins should be covered with solder

3.4 Mechanical Test

Items	Conditions	Specifications
Vibration	600-3300rpm amplitude 1.5mm 3 directions 2 H each	There shall be no damage.
Drop	On maple plate from 1m high 3 times	
Lead pull	Pull with 1kg force for 30 seconds	
Lead bend	90° bending with 500g weigh 2 times	

3.5 Voltage Discharge Test

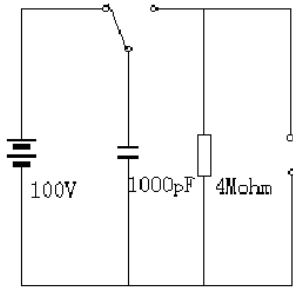
Item	Condition	Specifications
Surge	Between any two electrode 	There shall be no damage